

S 43 SX

TRUCK-MOUNTED CONCRETE PUMP
WITH 5-SECTION PLACING BOOM



SCHWING[®]



S 43 SX **HIGH UTILIZATION RZ5 BOOM**

Only Schwing combines Roll and Fold® and Z to create a unique boom ideal for overall pumping and placing efficiency. By putting the 270 degree Z-fold at the tip section, operators have unprecedented boom maneuverability. An added benefit of the five-section boom is a compact travel position. With a slewing range of 730 degrees, the boom adapts to many job sites. With standard EASy and EASy Flex one-sided outrigger systems and Super X Outriggers®, the footprint is reduced for access to sites normally restricted to long booms. With a 213 cu.yd./hr. pump kit and Big Rock Valve, the S 43 SX may be your most popular pump.

STANDARD FEATURES

Boom

Only Schwing combines Roll and Fold® and Z to create a unique boom ideal for overall pumping and placing efficiency. By putting the 270 degree Z-fold at the tip section, operators have unprecedented boom maneuverability. An added benefit of the five-section boom is a compact travel position. With a slewing range of 730 degrees, the boom adapts to many job sites.



Pump Kit

Continuous refinement makes the Schwing pump smooth, reliable and low maintenance, delivering millions of yards of concrete through booms around the world.

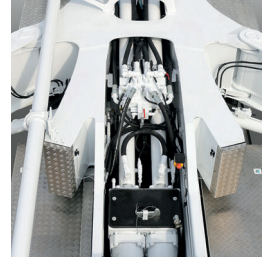

SX Outriggers

Exclusive design provides maximum stability with a smaller footprint on tight job sites. The curved front outriggers extend out and around obstacles, allowing placement of the pump as close to the pour area as possible.

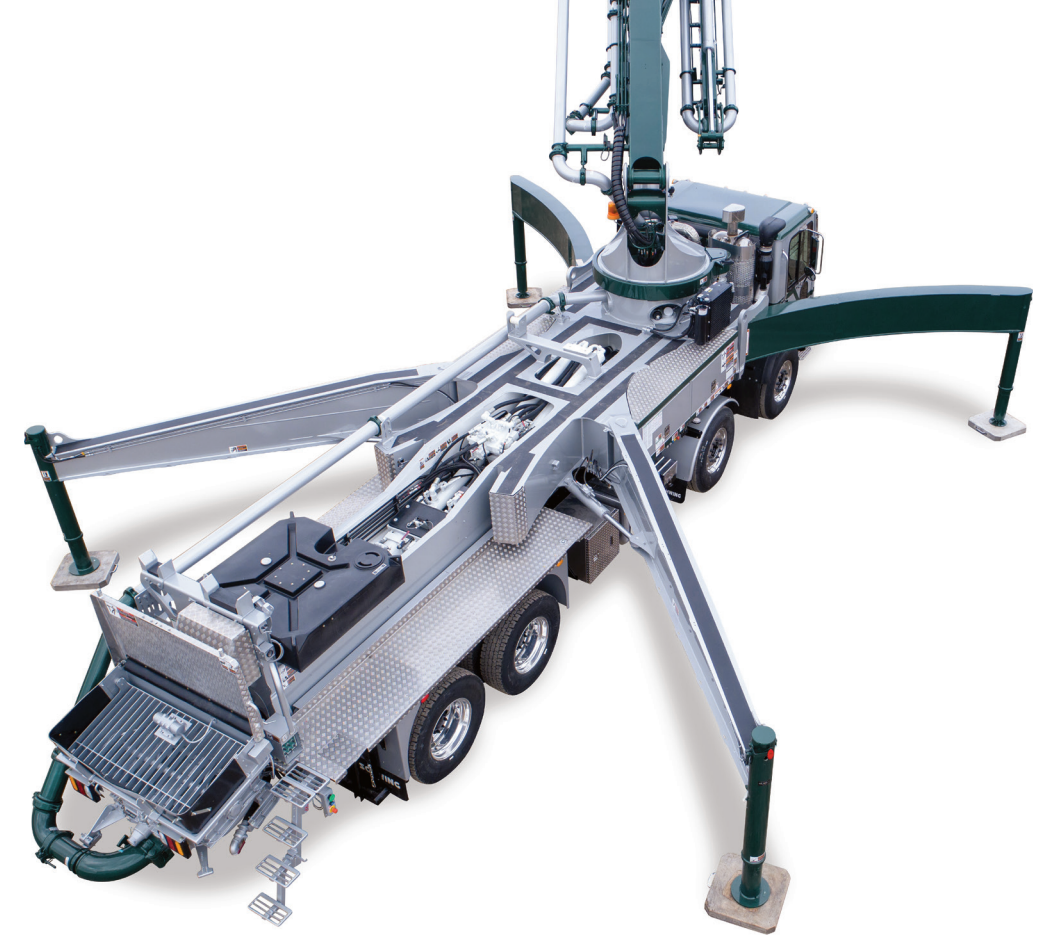

Open Loop Hydraulic System

The S 43 SX converts the engine power efficiently into pump power for fuel savings. Faster hydraulic switching means smoother pumping.



Rock Valve™

Nothing combines low cost-per-yard, low maintenance costs, and the ease of rebuilding like the Rock Valve™. As the most accessible valve in the industry, it is an operator's friend, shortening clean-up time while using less water. Ease of servicing and fewer replacement parts increase pump availability for higher return on your investment.

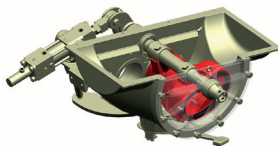

Convenient Control

Centralized control of the water box, water pump, agitator, spray hose and optional high pressure cleaner is an operator-friendly feature that translates to efficiency and profitability.



VECTOR Remote

The VECTOR remote system provides proportional functions and communicates with the operator to stay fully informed of pump status. It also monitors the boom position in EASy Flex mode to ensure the safety of the operator and pump.



VECTOR Control

The operator can review machine data, operating conditions and settings on the S 43 SX through the VECTOR control panel. The integrated diagnostic system ensures safe operation and also reminds the operator when maintenance is necessary.



ADVANTAGES & BENEFITS

THE ROCK VALVE™. EXTREMELY ROBUST.

Faster cleanup with less water.

The Big Rock Valve™ features an extended housing to easily keep up with the requirements of high volume pours even with the harshest mixes. Carbide wear parts extend maintenance intervals.

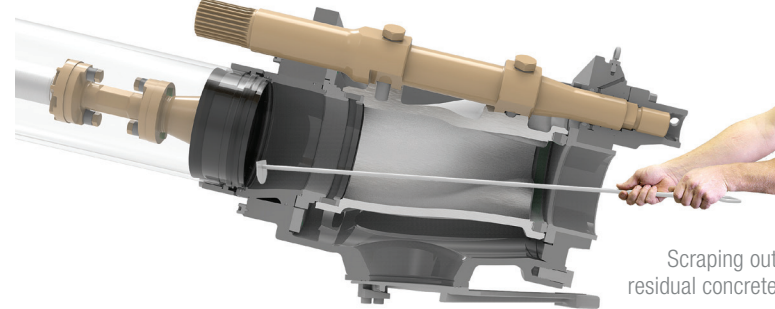

EASY MAINTENANCE

Maintenance of the Rock Valve™ is simple, fast and safe!

The Rock Valve™ not only has a much longer life than other concrete valves, it is also easier to maintain. After removing the housing cover, the wear parts are easily accessible and can be replaced quickly and safely. Time-consuming adjustments are not required after replacement. The Rock Valve™ contains only 15 wear parts – half the amount of competitors' concrete valves.

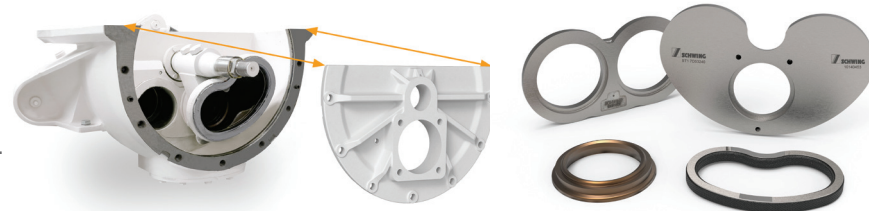

SUPER X OUTRIGGERS®

Less set-up space, more flexibility.

Exclusive Super X Outriggers® set up fast and provide maximum stability with a smaller footprint for more effective pumping on tight job sites. These curved front single-stage outriggers telescope out and around obstacles allowing placement of the pump as close to the pour area as possible. This means maximum utilization of the boom reach and more yards of concrete poured from a single set-up. By retracting along the sides of the truck chassis, the Super X Outriggers® allow for the large diameter, long stroking material cylinders down the center of the pump, that provide smooth operation and less wear than conventional concrete pumps.

THE LONG-STROKE PUMP KIT 2525H-6

Less wear, more profit.

The Super X Outriggers® make room for long material cylinders in the S 43 SX, resulting in 15% fewer pump strokes to achieve maximum output. This also contributes to improved wear, longer life and continuous pumping profits with less maintenance and more uptime.

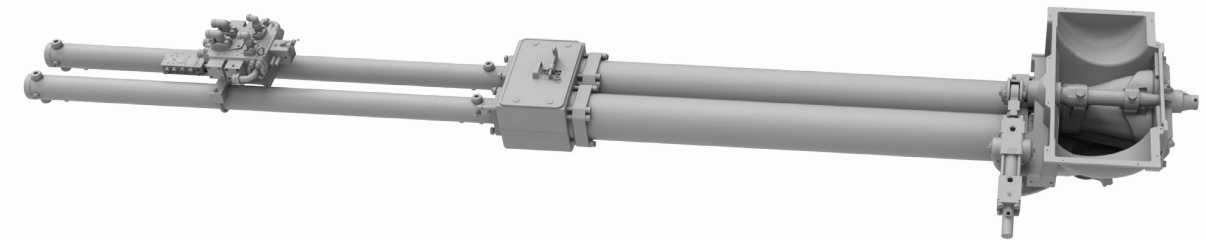

THE 43 METER BOOM

More rotation allows set-up in any position to reach the pour area.

Utilize the full 730 degree rotation of the turret (365 degrees in either direction) for significantly more flexibility when positioning the pump.

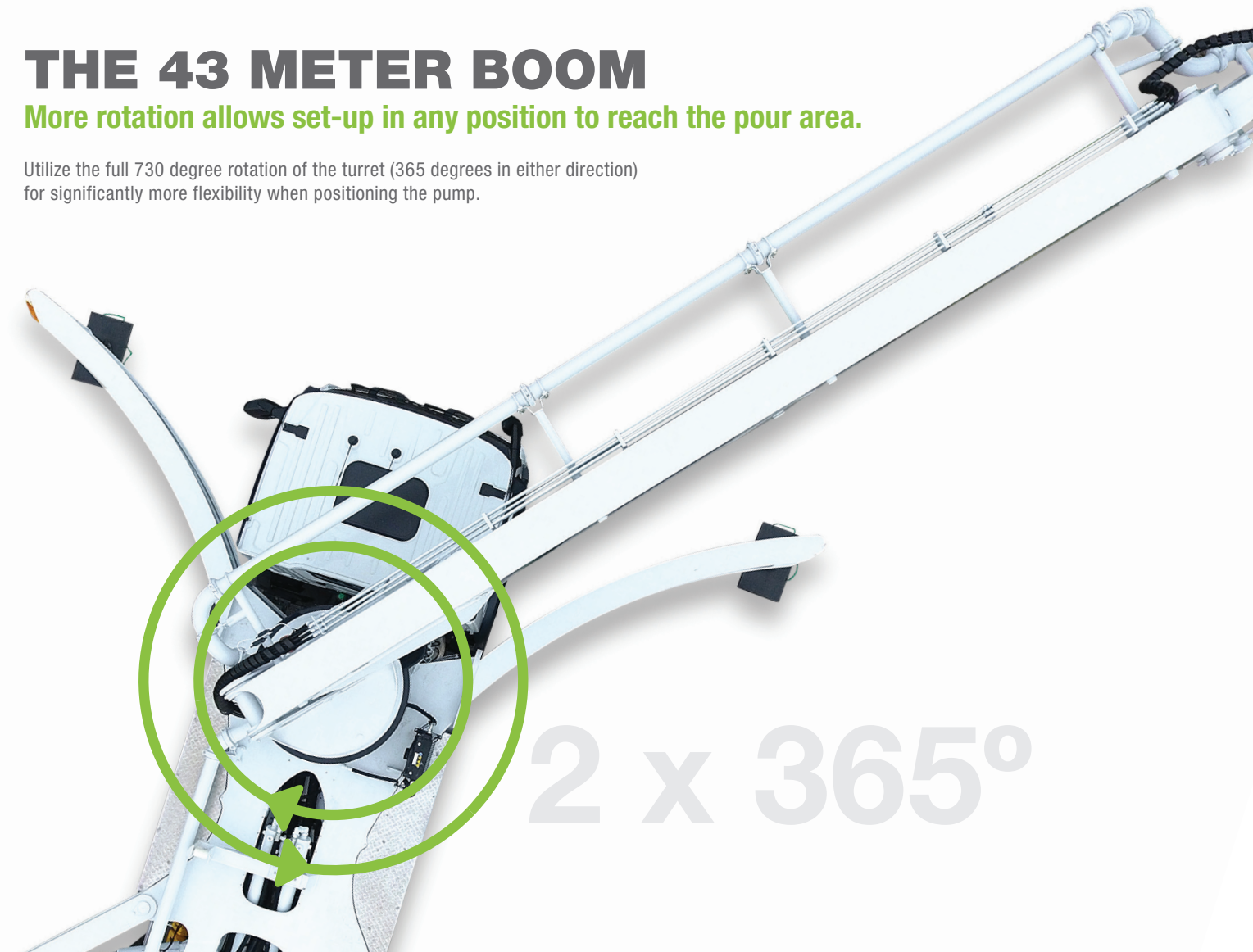

EASy & EASy FLEX

EASy
EASyflex

The one-sided outrigger systems, EASy and EASy Flex, extend the range of applications. With EASy, the concrete pump can be supported on one side and cover a working range of 135 degrees. EASy Flex provides further outrigger combinations for more flexibility on the jobsite. All one-sided outrigger configurations are monitored by the VECTOR Control system to assure the safety of the pump and operator.

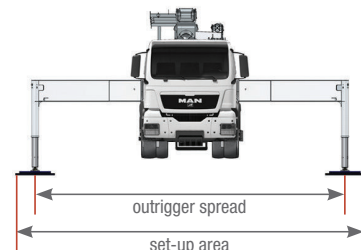
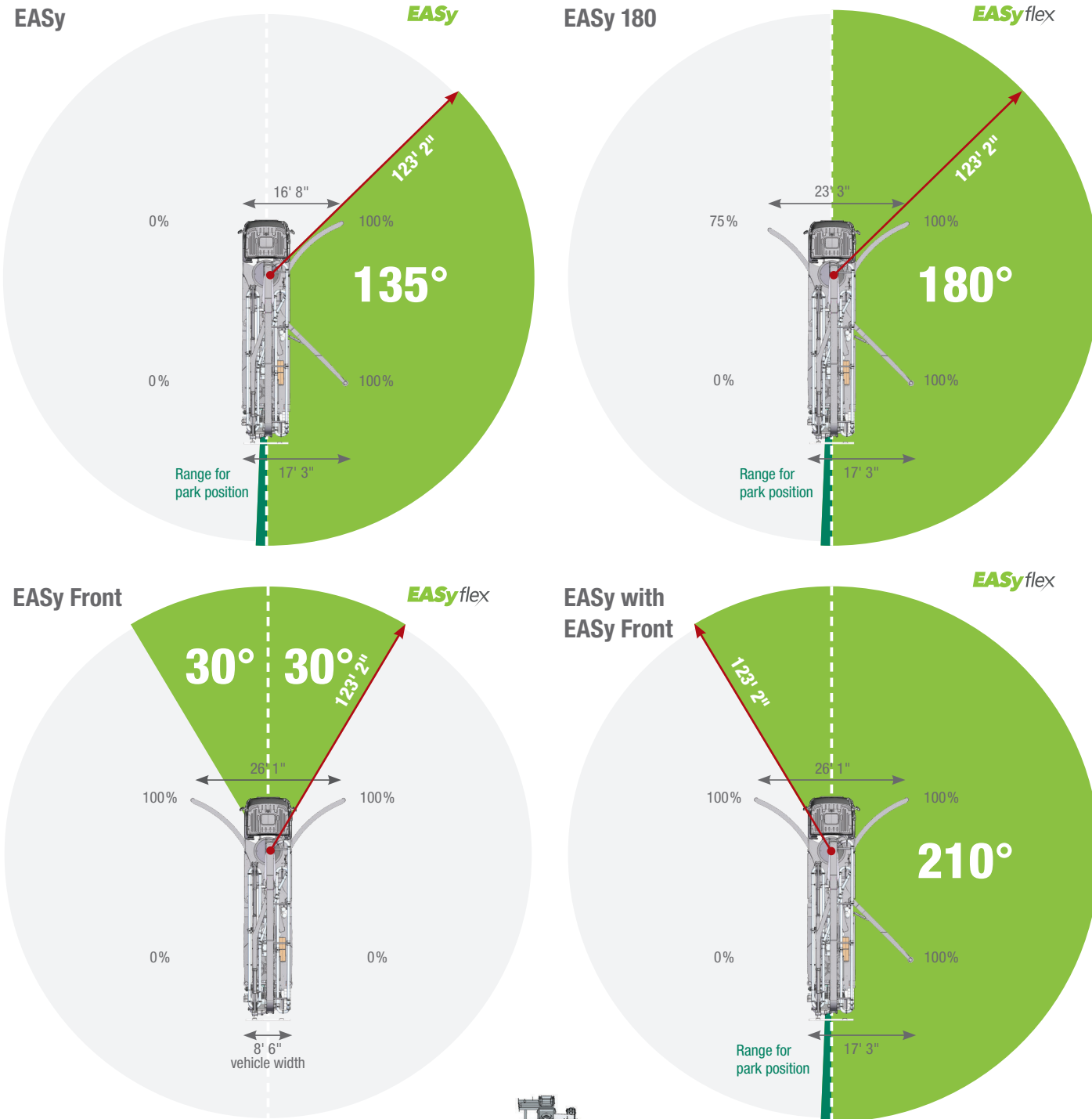

The outrigger spreads as specified are measured from the center of the outrigger leg. Any cribbing or underlay timbers must be taken into account when determining the required set-up area.

WORKING RANGE

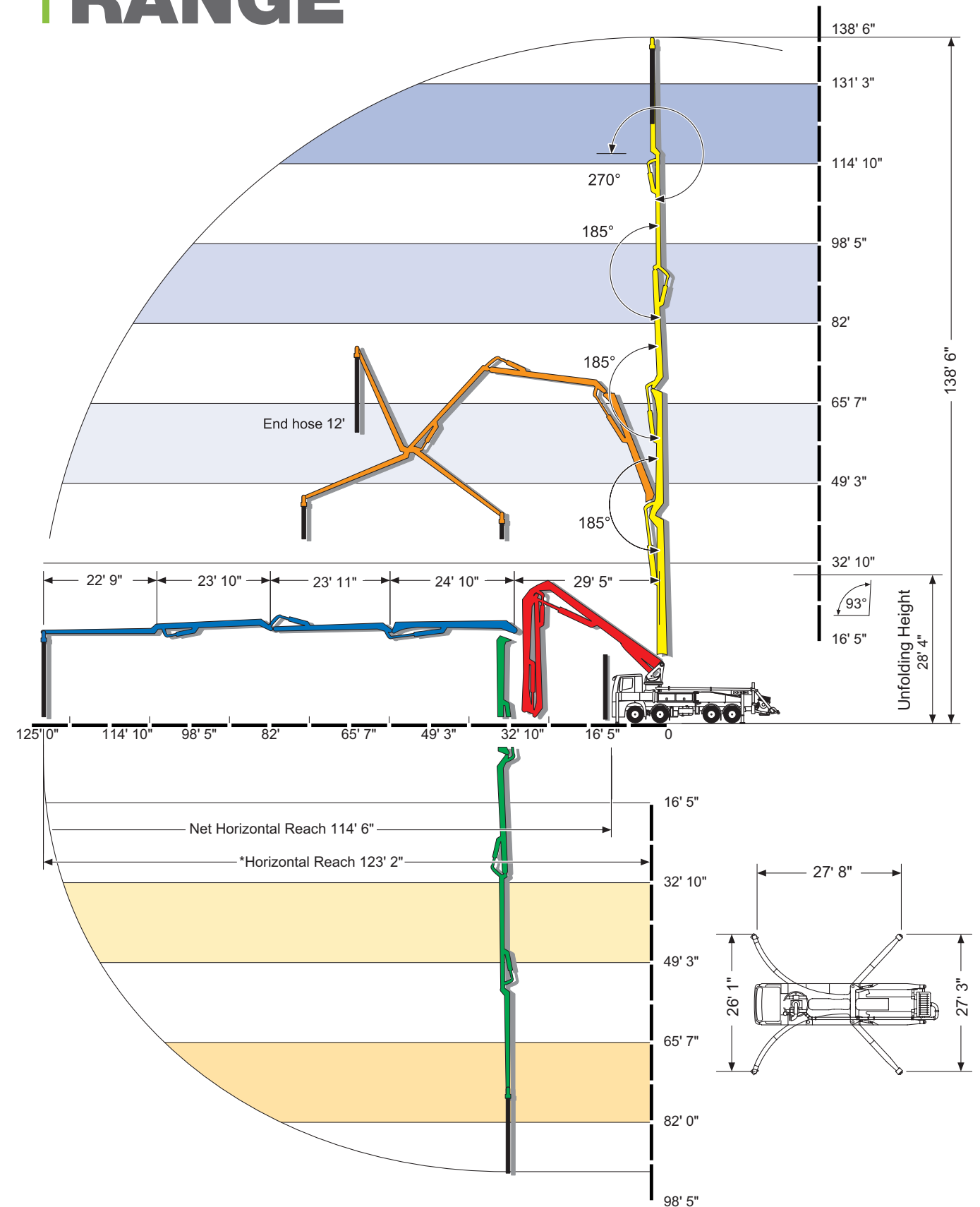

*Measured from the center of the turret to the end of the boom hose.

SPECIFICATIONS

S 43 SX

Pump Kits	2025H-6 120/85 MPS	
	U.S.	Metric
Theor. Concrete Output Per Hour (cubic yards - cubic meters)	213	163
Maximum Pressure on Concrete (psi - bar)	1169	81
Strokes Per Minute	22	
Material Cylinder Diameter (in. - mm)	10	254
Material Cylinder Stroke Length (in. - mm)	98	2500
Differential Cylinder Size (in. - mm)	4.7	120
Valve Type	B Rock	
Maximum Aggregate Size (in. - mm)	2.5	63.5

Boom Specifications

Pipeline Diameter (in. - mm)	5	125
Vertical Reach (ft.-in. - m)	138-6	42.3
Horizontal Reach (ft.-in. - m)	123-2	37.5
Net Horizontal Reach (ft.-in. - m)	114-6	34.9
Unfolding Height (ft.-in. - m)	28-4	8.6
Slewing Range	730°	
End Hose Length (ft. - m)	12	3.6
Boom Type	5 Section – RZ5 Roll & Fold®	

Section Lengths

First Section (ft.-in. - m)	29-5	8
Second Section (ft.-in. - m)	24-10	7.57
Third Section (ft.-in. - m)	23-11	7.3
Fourth Section (ft.-in. - m)	23-10	7.27
Fifth Section (ft.-in. - m)	22-9	6.94

Outriggers

Design (front)	Super X, Hydraulic Slewing & Jacking	
Design (rear)	Hydraulic Slewing & Jacking	
Front Width (ft.-in. - m)	26-1	7.95
Rear Width (ft.-in. - m)	27-3	8.31
Length (ft.-in. - m)	27-8	8.43
Load Front (lbs. - kg)	53,954	24,473
Load Rear (lbs. - kg)	53,954	24,473
Soil Pressure with Dunnage (front/rear)	96/96 psi	4.76/4.76 bar
Soil Pressure without Dunnage (front/rear)	770/420 psi	53.01/28.96 bar
EASy 135° Set-up Front (ft.-in. - m)	16-8	5.08
EASy 135° Set-up Rear (ft.-in. - m)	17-3	5.26

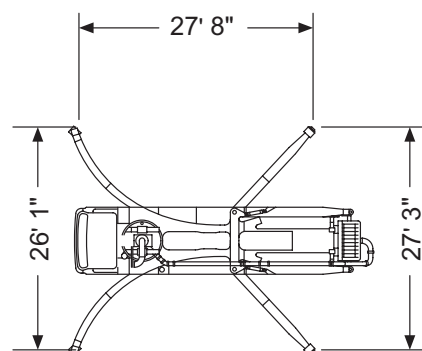

Specifications are subject to change without notice.





5900 Centerville Road | St. Paul, MN 55127
1-888-SCHWING | FAX 651-429-3464 | www.schwing.com